



ARTEOR™ | FLOW OF ENERGIES

 legrand®





## FLOW OF ENERGIES

Imagine that your home comes to life. That the walls, throughout the home, are suddenly gifted with intelligence, and watch over your daily well-being. Then imagine that you can control everything with a simple gesture, in a series of actions orchestrated exactly according to your wishes... This impetus, capable of bringing life to your living space, is the flow of energy provided by Legrand technology. Quite simply a new way of seeing the world, which we invite you to share.





**PIERRE-YVES PANIS ET DENYS TOULEMONDE**  
ARE DESIGNERS AT LEGRAND.  
THEY ARE HERE TO TELL US ABOUT THE GENESIS OF THE NEW ARTEOR™  
INTERNATIONAL LINE.

**What is the designer's role in creating a project such as Arteor™?**

Whatever his field of activity, the designer must find the optimum balance between function and form. This requires him to innovate constantly, even if that means changing habits and presuppositions.

As for Industrial Design, it is now at the core of a strategic issue: technological innovation. It forms the vital link between increasingly sophisticated electronic components, ever more elaborate functionalities, and a user who expects increasingly simple access solutions. Now, a product must be efficient, intuitive and elegant, indeed status enhancing. The factors of differentiation and perceived quality have in fact become essential choice criteria, both for consumers and for specifiers.

Our role is therefore to be at the forefront by capturing the current climate and anticipating trends. That's why Legrand Design keeps a "creative watch" on Architecture and Design to determine trends. Each designer then interprets them with his own particular style.

In this intuitive and imaginative work, creativity and rationality combine to create an end product.

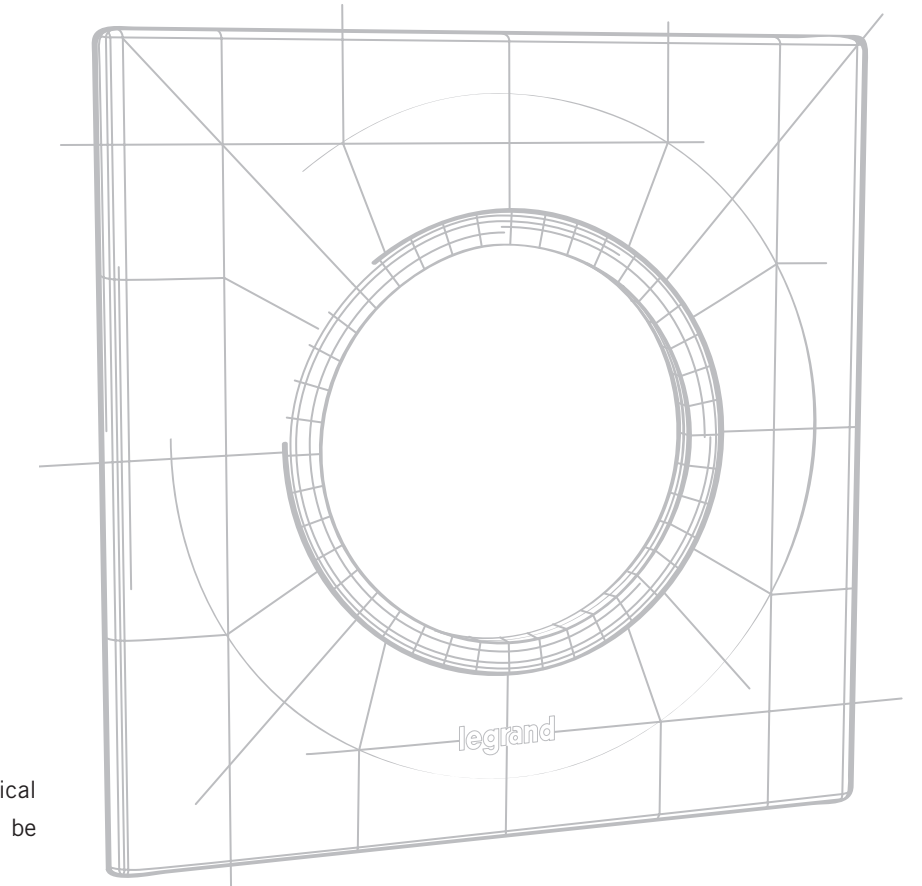
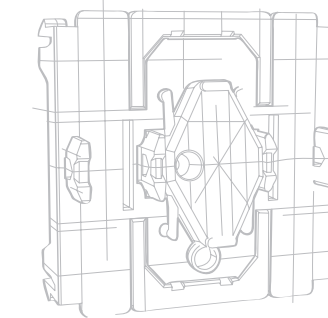
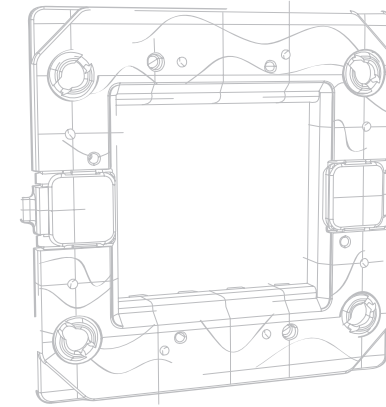

**How did the Arteor™ project take shape?**

Firstly, Arteor™ had to encompass all the technological know-how of Legrand. With several key parameters to be included:

- A top-of-the-range positioning, ensuring Arteor™ has a status enhancing value.
- A simple, clean style, sufficiently universal to be adapted to the different international markets.

Having chosen to refer to certain values of Asian culture, it seemed to us essential to develop this project in close cooperation with an Asian Industrial Design agency.

On a creative level, this partnership shows our willingness to increase intercultural and international exchanges as sources of inspiration and a first step towards a universal convergence.

It also confirms our willingness to coordinate talent and highlight the international dimension of our project. This synergy is the key to truly innovative proposals.

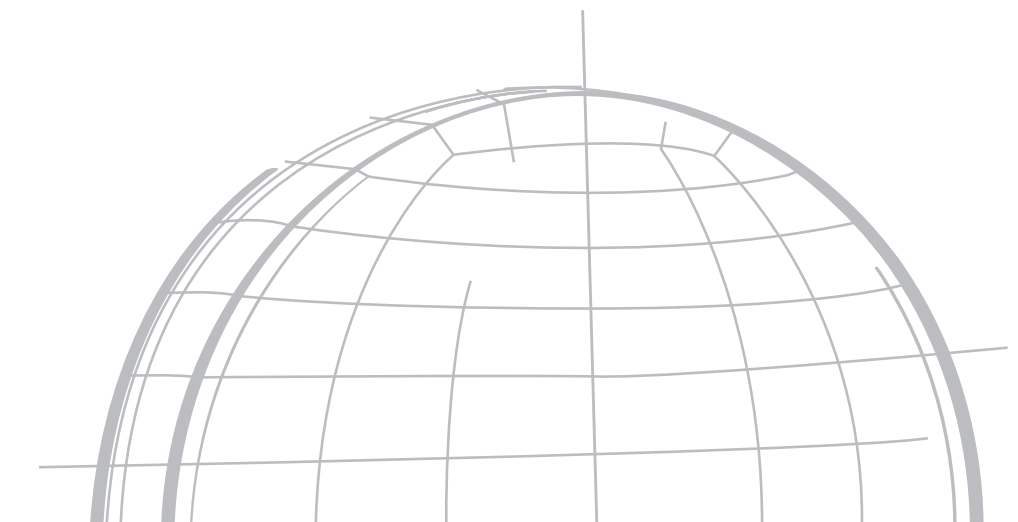
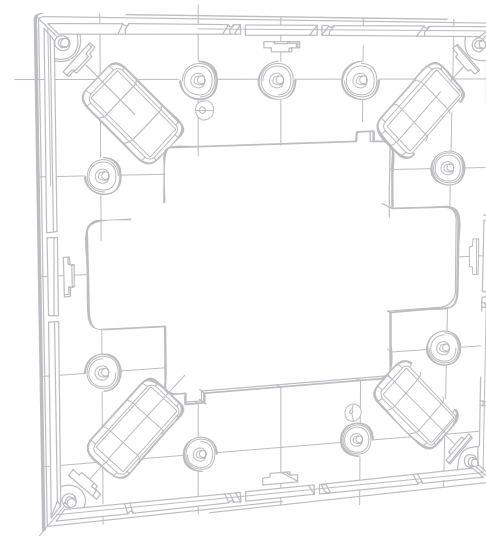

**In what way is the Arteor™ design innovative?**

From a formal point of view, Arteor™ innovates through its bevelled profile. By a visual effect, the object appears to float in space, weightless, bestowing unique elegance on the room.

Moreover, its lines echo those of high-tech objects increasingly found in interiors: flat screens, digital photo mounts, and computer screens.

With Arteor™, wiring devices are perfectly in line with new technologies.

***“With Arteor™, wiring devices are perfectly in line with new technologies.”***



**What are the constraints encountered during a project of this scale?**

Paradoxically, the thousands of kilometres separating our workshop and the Asian studio did not present an obstacle in the email age. The geographical distance does not imply a "creative" distance and we found that we share values and sensibilities.

The challenge, in an international endeavour, is to adapt to the constraints of each country. These may be subjective: preferences, effects of fashion, habits... Others are real enough, such as the shape of the rocker plate or the standards and local uses. We needed to develop a concept to offer the range in different standards while maintaining aesthetic consistency.



**Why offer two versions: round and square rocker plate?**

We think that the user needs to have this choice. We therefore offer a widest range where the options may be freely combined. The elementary and essential shapes – the circle and the square – ensure the multiple functions of modern wiring devices are harmoniously integrated.

Furthermore, each version has its own advantages.

We have therefore rethought the traditional square rocker plate so as to equip it with better ergonomics: a slightly concave surface facilitates the handling.

The difference is also visually noticeable and creates harmonious variations on surface composition.

The circle theme is innovative for this type of product. We could talk about collective influences because the European and Asian teams had the idea simultaneously, even before they shared their ideas.

Proof that this audacious solution was ideally adapted to the aspirations of users throughout the world.

The newness is not only aesthetic: the ergonomics have also been improved by this circle theme which allows the hand to move in a more natural, intuitive way.

It is surely not by mere chance that the circle is a significant trend in certain everyday high-tech appliances.

***“The round shape ensures the functions of modern wiring devices are harmoniously integrated.”***

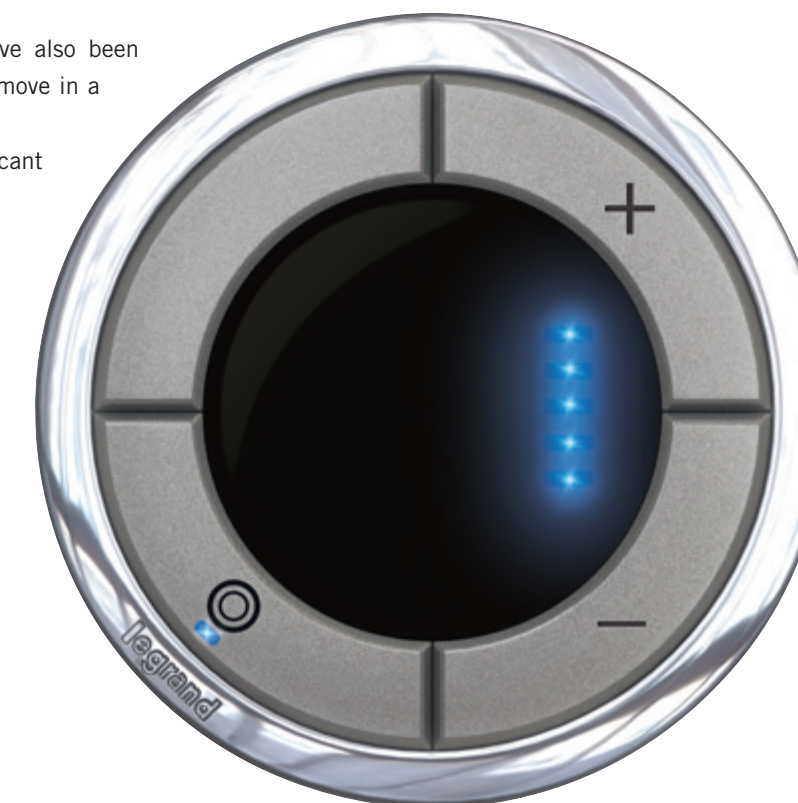



# Materials

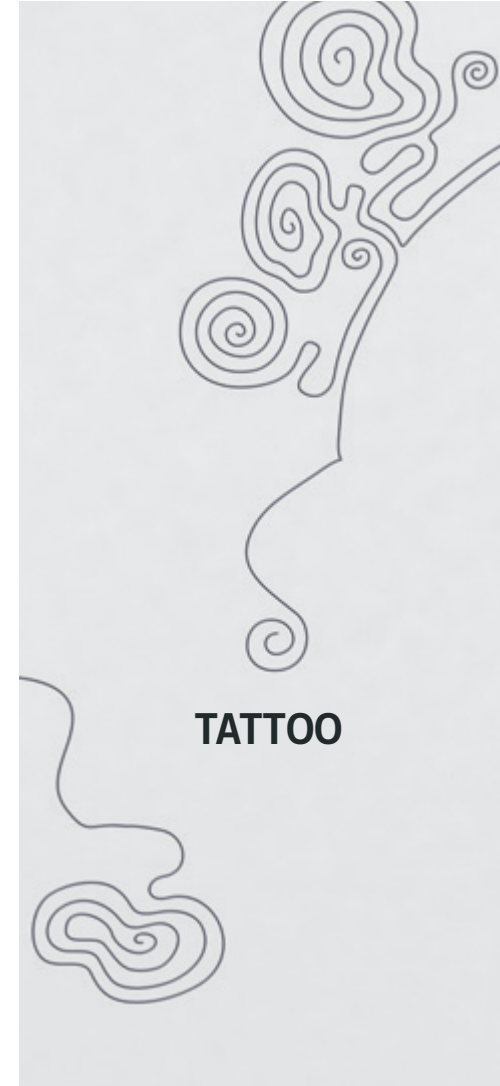

TATTOO

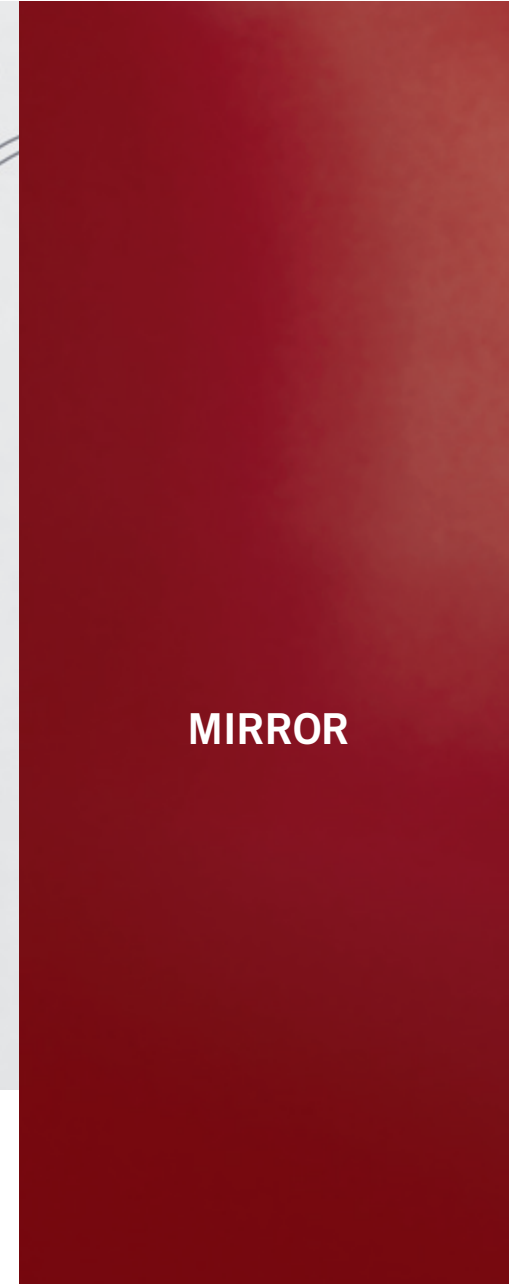

MIRROR

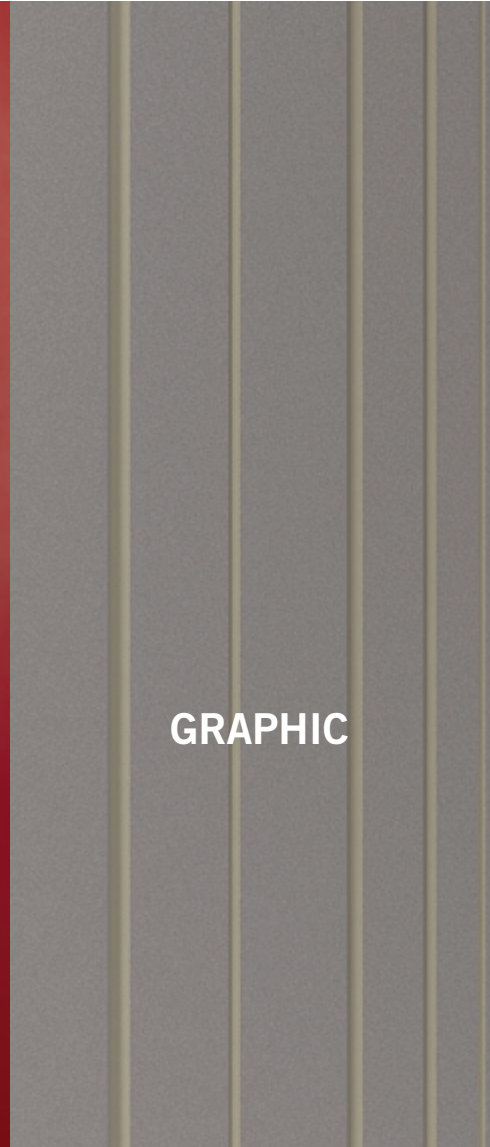

GRAPHIC

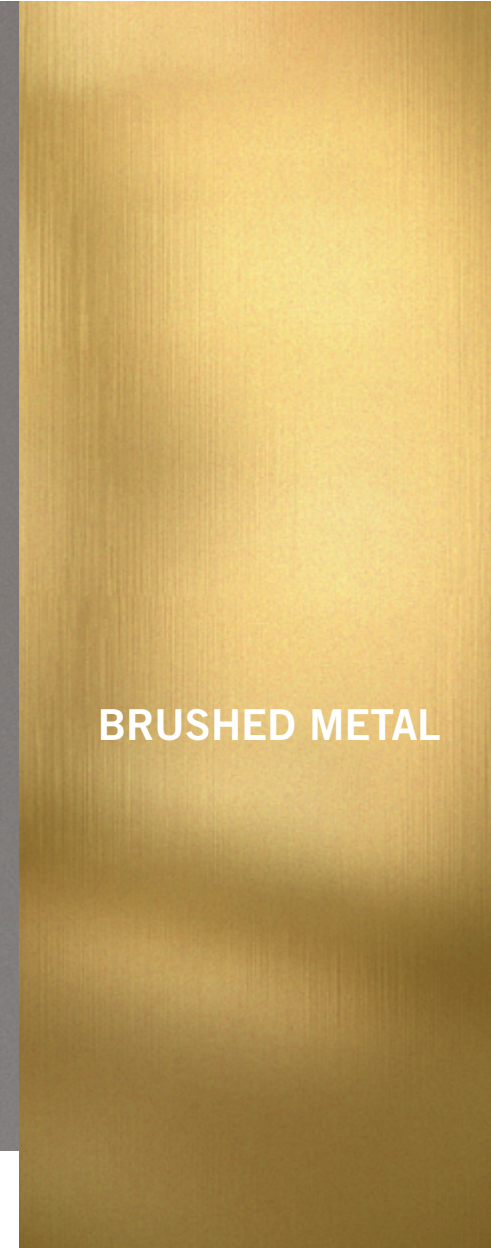

BRUSHED METAL



LEATHER



SIGNATURE

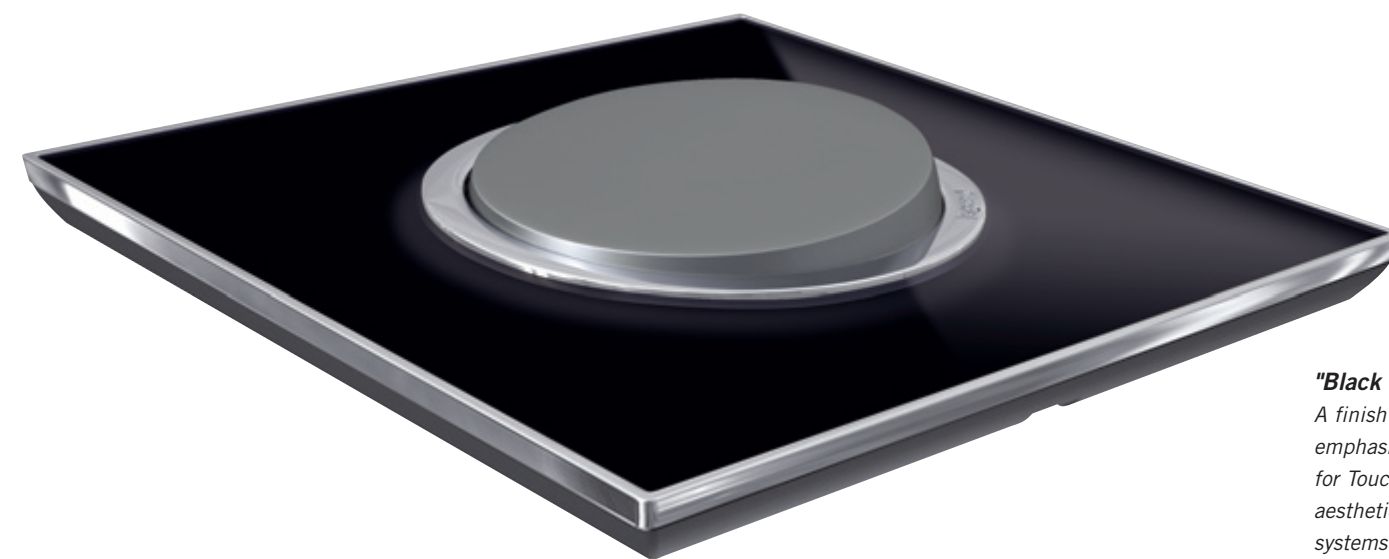

**"Black Mirror":**

A finish that harmonises with the world of flat screens and emphasises the "high-tech" nature of the collection. Offered for Touch products, it ensures in an exemplary way the aesthetic unity between classic wiring devices and advanced systems from the Arteur™ range.

***"Particular attention is therefore paid to the selection and quality of materials."***

**How have you obtained these effects of original materials?**  
The Arteur™ range contains a very high level of detail. Particular attention is therefore paid to the selection and quality of materials, from the most refined to the most innovative. Among the exclusive finishes offered, there is woven metal, red mirror and galuchat (shagreen or fish skin). In this endeavour, the Design team relies on the expertise of its specialist in materials and finishes. It is always seeking new trends through to its constant observation of external markets in the most diverse sectors: decoration, electronics, cars, lighting, furniture... Also, the experience of different cultures acquired during trips abroad, visits to trade fairs and material libraries, enables us to offer the user diversity of choice, and extensive adaptability in terms of decoration and lifestyle. Lastly, a manufacturer's expertise is also the art of using and producing materials with consistent quality.



*“The Arteor™ functions and applications can be customised at will. Imagination is the only limit.”*



**Arteor™ functions can be customised. Why have you provided this choice?**

Nowadays there is a real convergence of technologies, together with a high requirement for customisation. Today's objects of value are often by nature not definitive, in the sense of adaptability: from the computer to the mobile telephone or the car, all are intended to adapt exactly to the needs of each person. Arteor™ functions can be customised because users create their own living scenarios, set according to their preferences: cinema ambiance or an evening with friends, subdued lighting

with automatic closing of the curtains and adjustment of the thermostat... Imagination is the only limit. The system then becomes the home's brain. The creation of our icons is part of this philosophy. They have been specially designed to improve clarity and be immediately legible, in order to be highly user friendly. In contrast to a word, an icon is easily identifiable by the majority of people and enables a function to be encompassed in a gesture. It is the ultimate expression of technological convergence.



**ENVIRONMENT**

**Un enjeu pour Legrand**

Arteor™ is innovative not only through its design, it also provides answers to environmental challenges that enable optimisation of energy consumption in the home. The range includes a new generation of dimmers perfectly suited to controlling energy-efficient light sources such as compact fluorescent lamps and LEDs. It offers a variety of possibilities for programming and automation, and all its illuminated functions are equipped with LEDs.



**Is Arteor™ a response by Legrand to the major concerns of current Design?**

Yes, because the concept meets a real demand from the target public.

With nomadism and the mixing of cultures, the lifestyle of the individual is no longer fixed. Today users are in contact with a multitude of influences and viewpoints on a daily basis, when travelling or via the internet. This convergence of information sources and the virtual suppression of distances make them more likely to accept differences and build up their own values. This is conveyed for our department by a greater creative freedom. The Design team has therefore opted for a minimalist style in order to guarantee the timeless nature of the Arteor™ range, intended to live and evolve over the long term.

This corresponds to a real expectation of simplicity and authenticity. It is up to us, the designers, manufacturers and specifiers, to meet this demand in an appropriate way.

*“The lifestyle of the individual is no longer fixed.”*



Touch

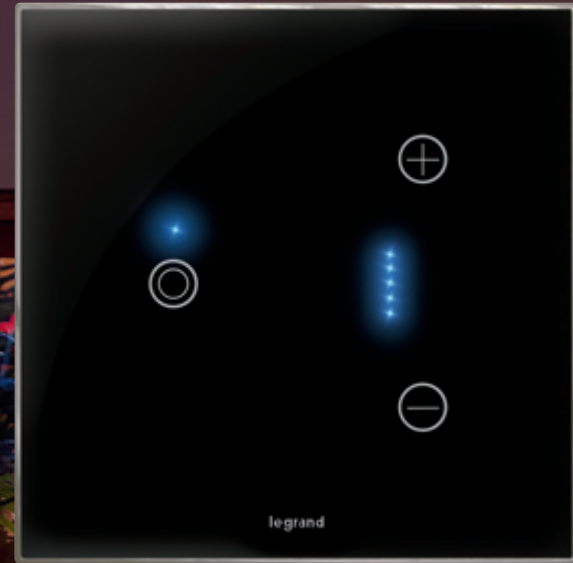

## TOUCH DIMMER LIGHT INTENSITY SELECTOR

From pure brilliance to the most subdued effect, choose your room's ambiance with a gentle touch of the hand. With its minimalist design and its elegant sensitive surface, the Touch Dimmer reinvents the art of controlling light.







## SCENARIO SWITCH ACTIVATOR OF SCENARIOS

With the Scenario Switch, you are offered a new way of setting the scene for your everyday life. With a simple press, you can activate real living scenarios that can be customised to control with a simple touch and simultaneously different functions in the room (light, heating, shutter, etc), programme a cosy ambiance and watch television, or start the hi-fi system and lights as soon as you arrive... Technology yields to your wishes.



Visualise



### 1.2" TOUCH SCREEN MULTIFUNCTION INTERFACE

The functionalities of the Scenario Switch are made more precise by an integrated control screen. Adjusting the temperature to the nearest degree – or choosing your favourite radio station – has never been so easy. All clearly expressed with the 1.2" Touch Screen.





**3.5" TOUCH SCREEN  
CONTROL CENTRE**

With the 3.5" Touch Screen, you can control all your systems in the home: lighting, roller shutters, sound system or alarm system. Now, custom-made living scenarios spread throughout the home and can be programmed according to your tastes and habits. The Touch Screen is also allows you to download your playlist via its IP entry, or turn up the sound while dimming down the spotlights. It offers numerous possibilities with a particularly intuitive navigation system, in the form of icons.



### 10" MULTIMEDIA TOUCH SCREEN VIDEO SYSTEM AND CONTROL CENTRE

When high-tech home automation brings life to the convergence of all the intelligent systems in the home... This control center adds video door entry and video surveillance to the home control functions - using the same intuitive navigation system as the 3.5" Touch screen. On its wide screen and depending on the number of cameras, controlling the exterior and interior of the home or talking with visitors has never been so easy. Also, its multimedia design provides access to multiple online services: radio, playlists, weather, traffic news, and even video broadcasts.





Sublimate



### SWITCH INTERIOR DESIGN

While Arteur™ innovates through its bevelled profile, it also offers many exclusive options: round rocker plate, colours and new materials such as galuchat (shagreen or fish skin) or woven metal... resulting in numerous combinations and a perfectly harmonious integration into your interior.





### LIGHT MOOD MANAGER

#### CREATOR OF LIGHT AMBIANCE WITH TOUCH SCREEN

Conference, projection, work meeting or showroom... With the Light Mood Manager you can adapt the lighting to the use of your space: area or centralised control, hourly programming and lighting scenarios provide the comfort and prestige that gives your company the edge.





## BEDSIDE UNIT TOUCH INTERFACE FOR HOTEL ROOMS

That comfortable feeling of being 'at home' even when you're far away comes from a multitude of small details. With this unit at their bedside, travellers will enjoy a perfect rest: The blinds, curtains and lighting can all be controlled remotely without having to get up. And programmable scenarios can be used to adapt the atmosphere to suit their mood.



From the elegant simplicity of the Neutral finishes to the extreme refinement of the Signature line, a collection rich in choice and fine materials. To make each room a truly unique.

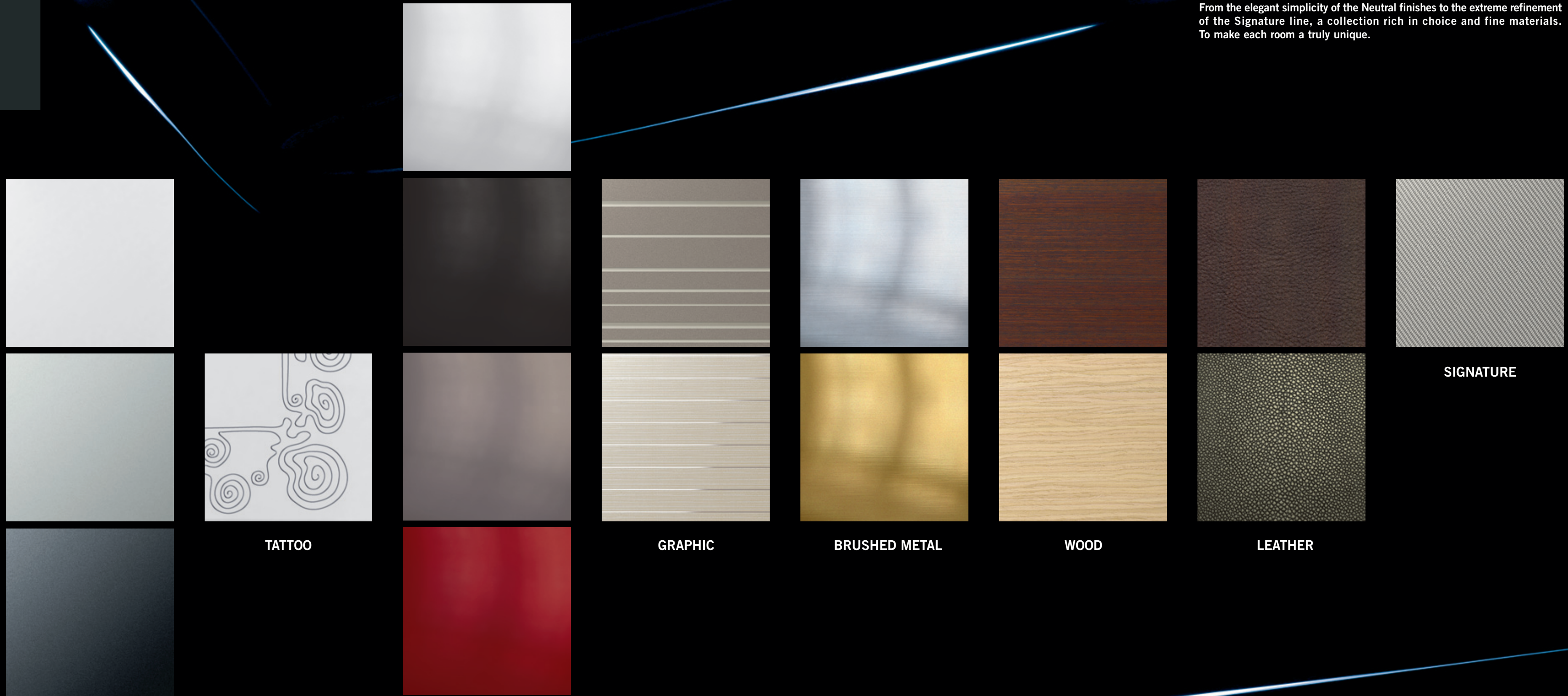

NEUTRAL

TATTOO

MIRROR

GRAPHIC

BRUSHED METAL

WOOD

LEATHER

SIGNATURE



Choose

Diversity of colours, materials and designs, but also à-la-carte ergonomics with the choice of a round or square rocker plate... The Arteor™ collection lends itself to infinite combinations to match your style.

NEUTRAL



White



legrand



legrand

Pearl aluminium



legrand



legrand

Graphite



legrand

TATTOO



Edition 1





In Mirror finish or in a Graphic version, Arteur™ plays on originality. High-tech or fantasy ambiance, you choose.

MIRROR



Mirror black



Mirror white



Mirror taupe



Mirror red



GRAPHIC



Casual



Formal





Finesse of the brushed metal against the warmth and authenticity of the wood: irresistibly elegant...

BRUSHED METAL

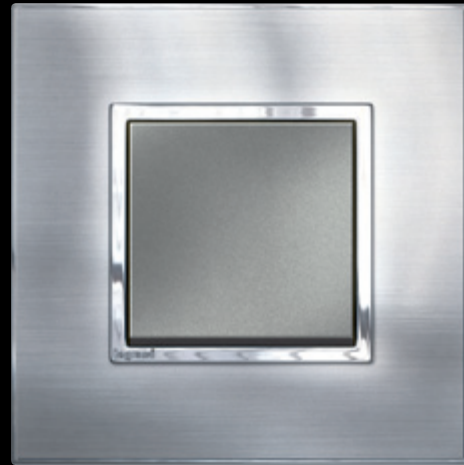

Stainless steel

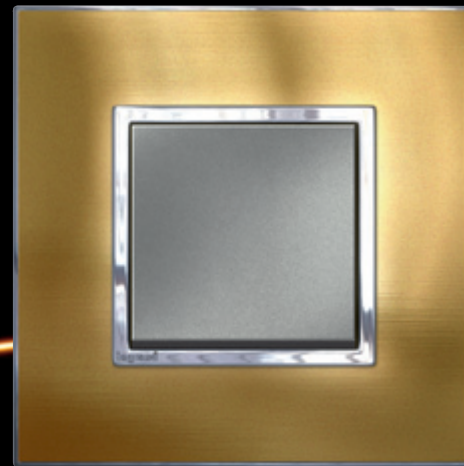

Gold brass

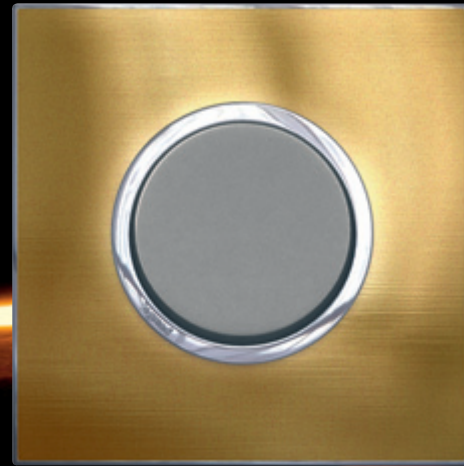

WOOD



Wenge style



Light oak





When fine and rare materials are used, exclusive collections are the result. This applies to galuchat (shagreen or fish skin) and woven metal: you will find them nowhere else.

LEATHER



Club



Galuchat



SIGNATURE

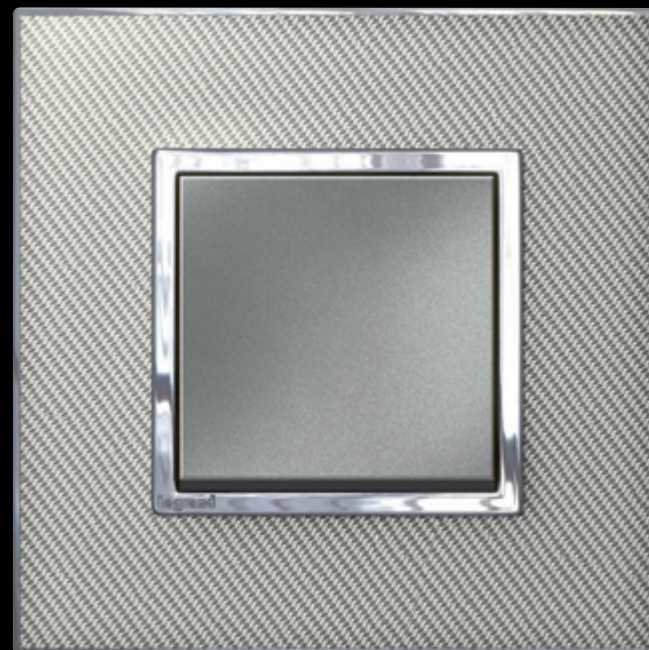

Braided metal





Right from the very first level our Home Automation range offers functions allowing a high degree of comfort. With a choice of ergonomics to suit your expectations: Micropush button, or Touch sensitive control. Arteor Home Automation solutions are based on two technologies: bus and radio.

MICROPUSH CONTROL



Micropush lighting control (BUS version)

DIMMER CONTROL



Dimmer control for 2 circuits

TOUCH PLATE SWITCH

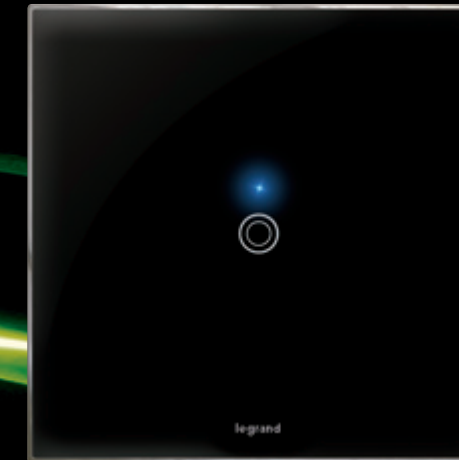

Touch plate switch (radio version)

TOUCH CONTROL

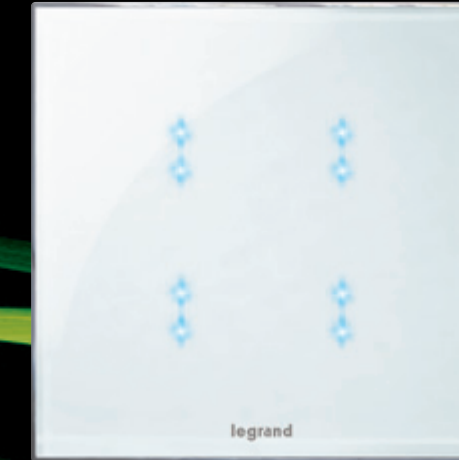

Lighting touch control (BUS version)

DIMMER



Leading/trailing edge radio dimmer without neutral

SHUTTER CONTROL



Micropush shutter control

TOUCH PLATE DIMMER



Touch plate dimmer (radio version)

TOUCH PLATE SHUTTER CONTROL



Touch plate shutter control (radio version)



Advanced Home Automation functionalities to create four living scenarios. Lighting, blinds, heating, hi-fi system... Controlling several functions with a single touch soon becomes second nature. Available in Micropush, touch plate or touch screen versions.

### 4-SCENARIO MICROPUSH



4-scenario micropush control (BUS version)



4-scenario micropush switch (radio version)

### 4-SCENARIO TOUCH

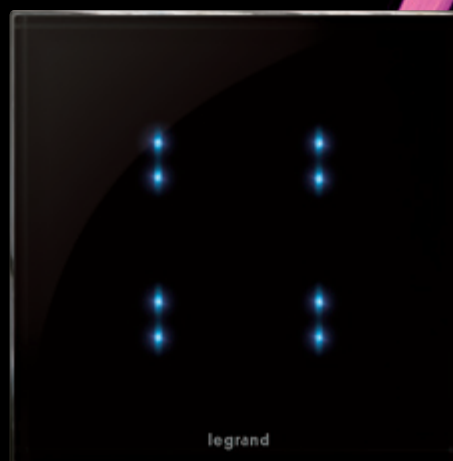

4-scenario touch control (BUS version)



Touch plate scenario controller (radio version)

### 1.2" TOUCH SCREEN



1.2" Touch screen in "sound distribution" mode



1.2" Touch screen in "temperature management" mode



From a single point control all the settings and multimedia functions in your home, set the lighting in the garden, control the gate... With the Home Automation screens, the interior and exterior become one.

HOME AUTOMATION



3.5" Touch screen:

**Control center**  
Enables the creation of scenarios for every room: lighting, shutters, sound system, temperature regulation, alarm system, etc. Touch technology controls and easy navigation using icons.



Video display

**Hands-free video door entry and home control station**  
Colour video screen and integrated microphone for welcoming visitors



10" Multimedia touchscreen

**Video system and control center**  
A control center for home control functions, video door entry and video surveillance functions via a control screen linked to indoor and outdoor cameras, and broadcasting of multimedia contents (web, video, etc.)



Comfort takes on another dimension with these switches that enable you to dim, control and connect in a modern way: movement detector, electronic thermostat... New ways to reconcile everyday comfort with a responsible lifestyle.

ALL-LOAD SWITCH



Micropush 2-way switch with LED locator

SENSITIVE SWITCH



Control light sources by simply passing the hand in front of it

ELECTRONIC ROOM THERMOSTAT



Active temperature management room by room

SKIRTING LIGHT WITH LED



Installed near obstacles for greater safety

UNIVERSAL DIMMER



Universal dimmer - suitable for compact fluorescent lamps

MULTI-OUTPUT DIMMER



Micropush dimmer for 2 circuits

TV/R/SAT SOCKET



For TV connection

TÉLÉPHONE SOCKET



For telephone connection



Offices and collective spaces require specific solutions and maximum flexibility: lighting adapted to each situation (meetings, conference, etc.), access security, comprehensive multimedia connections. The Arteor™ range meets all these expectations with perfect adaptability.

LIGHTING ENVIRONMENT CONTROLLER



Control 3 lighting circuits and create the right lighting environments especially in conference and meeting rooms

AUTOMATIC SWITCH



Switch on light only when needed - and switch it off automatically

SKIRTING LIGHT WITH DETECTOR



Installed near obstacles it automatically provides more safety

FINGERPRINT READER



The solution wherever an extra-high level of security is required

RJ 45 SOCKET



High-performance access to data

WIFI ACCESS POINT



Wireless access to communication networks and the internet. For maximum mobility



From the hotel room door to the bedside table, Arteor™ provides all the solutions for the specific needs of today's hotel industry. Comfort that extends to the hotel's communal areas, whether dedicated to relaxation or work.

EXTERNAL UNIT



Allows the staff to see the room status at a glance.

INTERNAL UNIT



Allows customers to select the desired setting: "Don't disturb" or "Make up room"

DATA AND MULTIMEDIA SOCKETS



Data and Multimedia sockets provide easy access to the Internet and allow to connect electronic devices such as MP3, digital cameras, portable dvd or laptops to the hotel TV system.

BEDSIDE UNIT



The bedside unit provides everything travellers need to control blinds, curtains and lighting from a single point without having to get up.

SOFT LIGHT DIFFUSER



Its soft, subdued light helps you to find your way in the dark but will not disturb your sleep.

MULTISTANDARD SOCKET



Enhances convenience for international customers as it allows connection without the use of an adaptor.



New technologies, new connections. Arteor™ adapts to all the digital developments in order to guarantee complete reliability. Internet sockets, data networks, Wi-Fi network, TV and USB sockets... At your home or office, easily connect computers, TVs, MP3s, audio and video equipment.

RJ 45



Data socket

WIFI ACCESS POINT WITH RJ 45 SOCKET

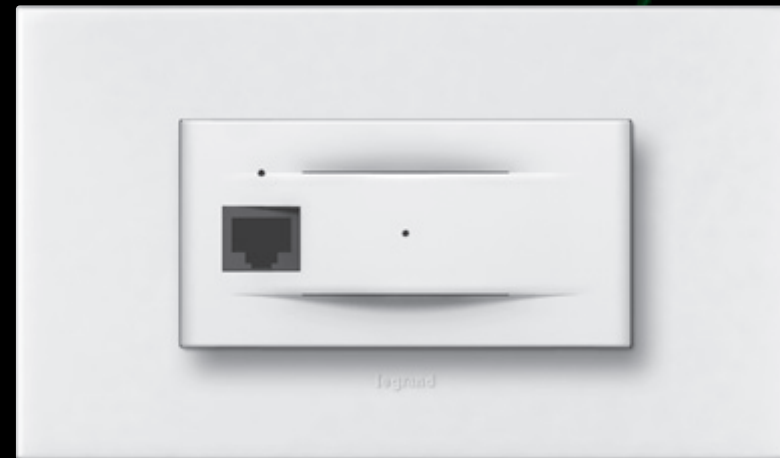

For wireless access to the internet and communication networks

YUV



For audio/video connection of a DVD drive, camera, video recorder or MP3 player

TRIPLE RCA

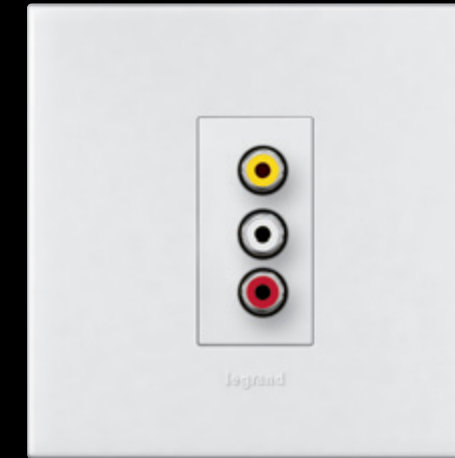

For audio/video connection of a DVD drive, camera, video recorder or MP3 player

USB



For connection of USB devices and for analog connection of a DVD drive, PC monitor

TV/R/SAT



For TV connection

HDMI



For digital high definition audio and video connection of a PC monitor, plasma screen, video projector

HD 15 / JACK



For analog video and audio stereo connection of a PC Monitor, plasma screen or videoprojector.



Designed to adapt to the majority of international standards, Arteor™ is the solution for all your projects, wherever they are in the world and whatever their destination: home, work, hotel...

AUSTRALIA



INDIA



EURO/US/CHINA



KOREA

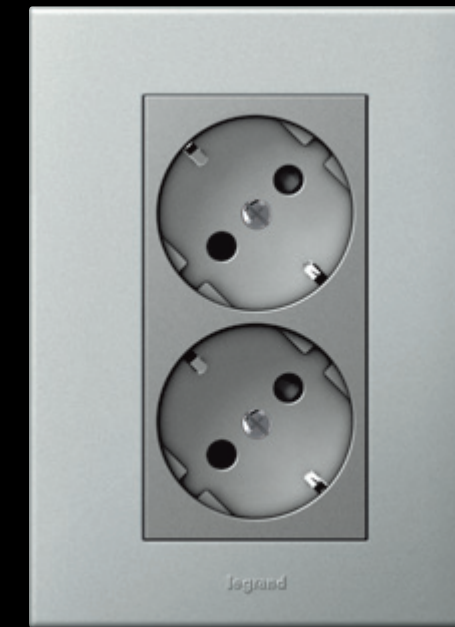

MULTI-STANDARD



BRITISH STANDARD

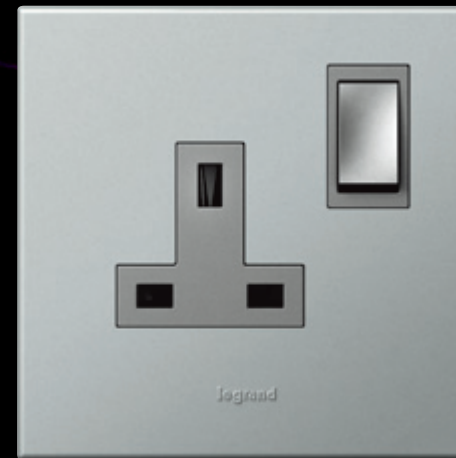

SOUTH AFRICA

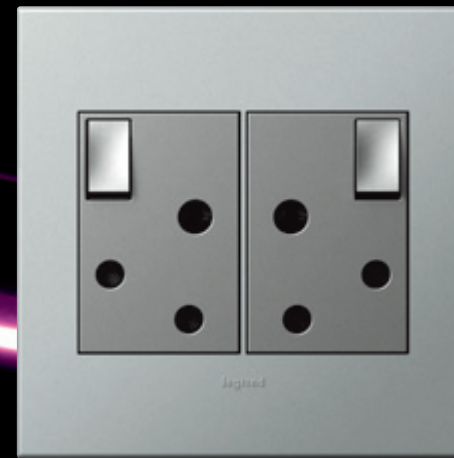

MIXED

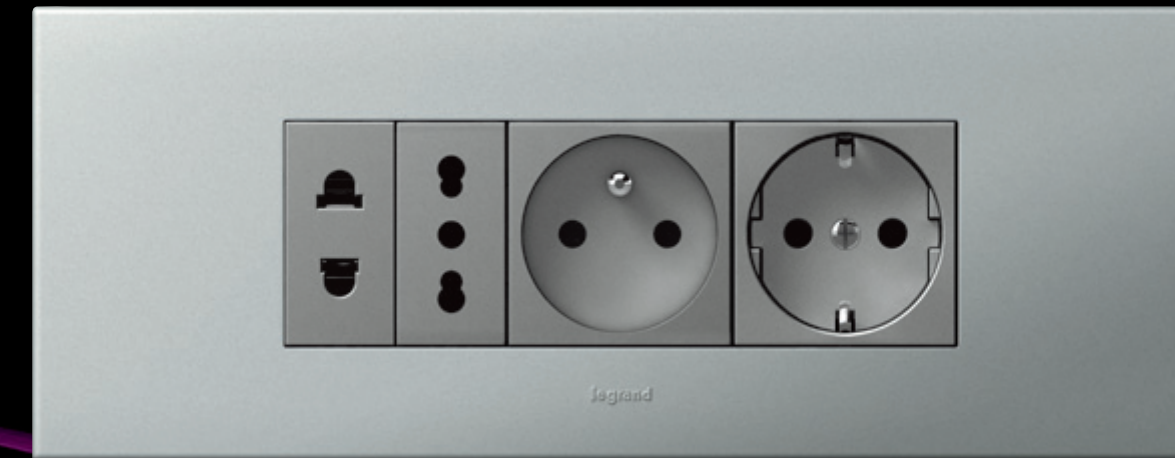

Euro/US, Italy, French and German standard



## SPACE WRITING

Tested by photographers as early as the first half of the 20<sup>th</sup> century, the purpose of Light Calligraphy is to capture the ephemeral. Certain famous names from Contemporary Art have tried it, equipped with a torch... Today, many refer to this movement inspired by graffiti and have developed their own techniques, based on a very specific set of gestures and complete mastery of the photographic processes. The flows presented in this piece are the work of the photographer Guillaume Béguin, who Legrand thanks for his contribution.

We would also like to thank the following for their valuable contribution:  
LIGNE ROSET, LES ANNEES LUMIERES, SENTOU (Coffee table / Design Isamu NOGUCHI), EDIFICE ("Turner" Candlesticks / Design Xavier Lust, "Phoenix" Coffee table / Design Patricia Urquiola, "Brasilia" Coffee table / Design F. & H. Campana, "Diderot I" Vase / Design Mendini, "Koishi" Pouffe / Design Naoto Fukasawa), SILVERA (TATINO Pouffe, TECTONA Lamp, FEEL Chair, Puppies), EDRA ("Flap" Sofa), MANDARINA DUCK (For the luggage room), LA MAISON DE L'ELEPHANT ("Gold Vase"), PAINTINGS (Laurent CAIROLI, FKDL - Franck DUVAL, Jean-Luc VALLEGAS).







 **legrand**<sup>®</sup>